

Virtual Band Camp

Skill Sheet #4 - Trumpet Fingering Chart and Note Exercises

To get different notes on the trumpet, you press down different combinations of valves. A Fingering Chart is a picture of which valves your fingers press for each note. Here's what the symbols on the Fingering Chart mean:

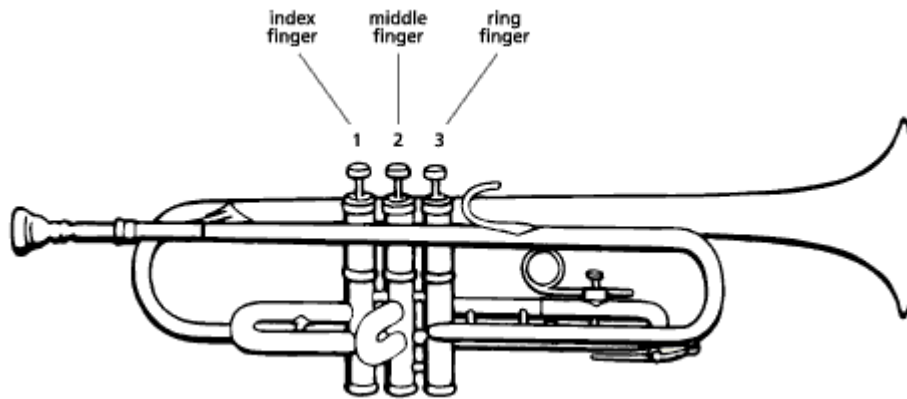

Fingering charts may show pictures of circles that represent each valve, or just list the number of each valve. Our chart lists the numbers. So, if you see a fingering "12" listed, that means you press down Finger #1 and Finger #2 at the same time.

Your First Fingering Chart

Here are the first notes you'll learn in band. This chart shows the notes written in musical notation, their names, and which valves to press in order to play them.

A musical staff in 4/4 time with a treble clef. Five whole notes are written on the staff: C (first space), D (second space), E (third space), F (first space), and G (second space). Below each note is its name and its fingering number in red text.

Note	Fingering
C	0
D	13
E	12
F	1
G	0

Please go to page 2! →

Trumpet Note and Fingering Exercises

1. The Note-Playing Process

- Find a note you'd like to play on the fingering chart, and see if you can do the fingering on your trumpet.
- Remember, if two numbers are listed, it means you press two valves at the same time!
- Keeping your fingers in position, form a good embouchure, and blow.
- Repeat this process until you've learned several notes!

2. Back and Forth

- Choose two notes that you've learned.
- See if you can play them one after the other, again and again. For example: C, D, C, D, C, D, C, D.
- Do this several times on as many different pairs of notes as you can.

3. Memory

- After you have a good idea of what each fingering is, pick one and study it carefully.
- Now, turn your fingering chart over and see if you can finger that note on your trumpet without looking.
- Once you've memorized one note, repeat the process to memorize the other notes.
- Can you have C, D, E, F, and G memorized by our first rehearsal?

4. Create Your Own Song

- Using the notes you know, create your own short song.
- After you play the song, see if you can say the note names you used in order.
- Do this as often as you can. You may even want to try playing songs for your family and friends!

Practice Chart

Each time you do one of the exercises above, check it off below. The more checks you get, the better you'll become at playing trumpet.

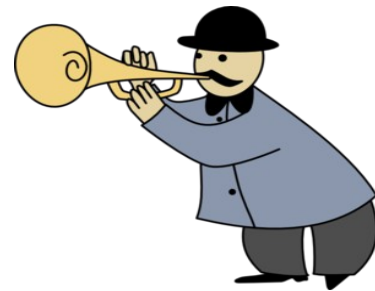

Exercise	Checks
The Note-Playing Process	
Back and Forth	
Memory	
Create Your Own Song	